

Contents

1 Product



AR-331-E



AR-331-EF

2 Terminal Cables

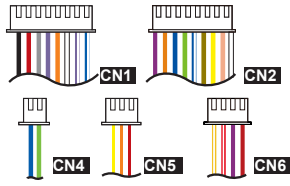

3 Tools

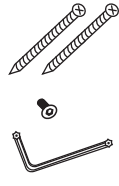

Flat Head Cap Philips
Tapping Screw: 4x20
Security Torx: M3x10
Security Torx Wrenches

4 Accessories

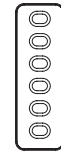

Rubber Pad

5 Option



RJ45



TCP/IP Module

Installation

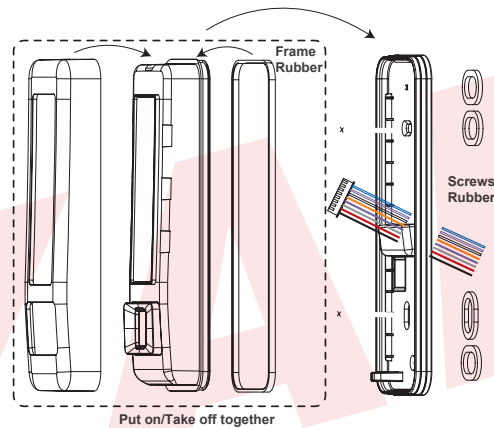
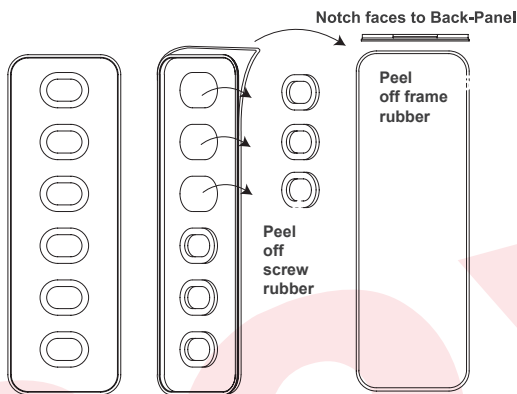

- Peel off screw hole rubbers and frame rubber from rubber pad
- Put screw rubbers on the back side of the mounting plate and pull the cables from the square hole of the mounting plate.
- Put a frame rubber on the frame groove of body

- Connect the terminal cables to the body and attach the body to the mounting plate.
- Assemble the covers with the Allen key and screws (accessories supplied). Turn on the power and LED will light and beep will sound.

Front Panel & Indicator

Left LED	Description	Right LED	Description
Blue	Arming / Blue LED Input (Active High)	Green	Power-on/Stand-by /OK
Yellow	Yellow LED Input (Active High)	Red	Error/Alarm

While power on the device, hands off the touch panel for 10 sec. to make sure a successful activation.



INSTALLATION

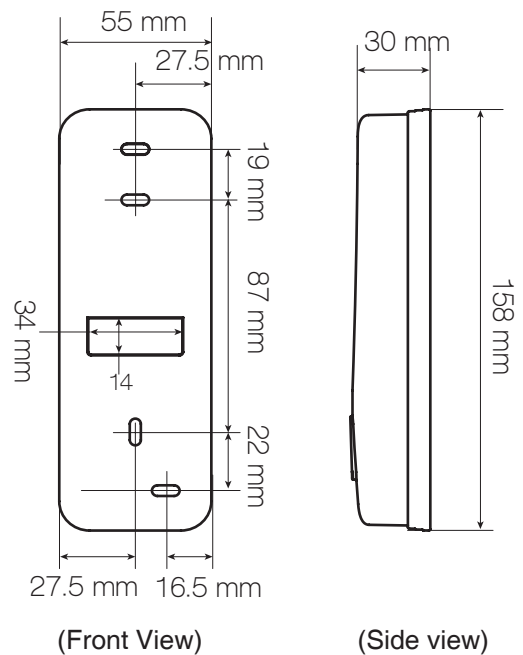

Connector Table

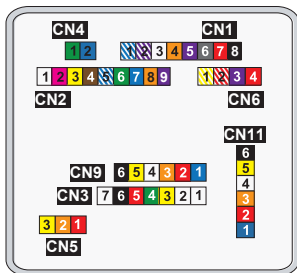

Cable: CN1

Wire Application	Wire	Color	Description
Lock Relay	1	Blue White	(N.O.)DC24V1Amp
	2	Purple White	(N.C.)DC24V1Amp
Common-COM-Point	3	White	(COM)DC24V1Amp
Door Sensor	4	Orange	Negative Trigger Input
Exit Switch	5	Purple	Negative Trigger Input
Alarm Relay	6	Gray	Transistor Output Max. 12V/100mA (Open Collector Active Low)
Power	7	Thick Red	DC 12V
	8	Thick Black	DC 0V

Cable: CN2

Wire Application	Wire	Color	Description
DI1	1	White	Reserved
Beeper	2	Pink	Beeper Output 5V/100mA, Low
LED	3	Yellow	Red LED Output 5V/20mA, Max
	4	Brown	Green LED Output 5V/20mA, Max
Door Output	5	Blue White	Transistor Output Max. 12V/100mA (Open Collector Active Low)
Wiegand	6	Thin Green	Wiegand DAT: 0 Input
	7	Thin Blue	Wiegand DAT: 1 Input
WG Door Sensor	8	Orange	Negative Trigger Input
WG Exit Switch	9	Purple	Negative Trigger Input

Cable: CN3

Wire Application	Wire	Color	Description
TCP/IP Output	1	---	---
	2	---	---
	3	Yellow	Net - TX+
	4	Green	Net - TX-
	5	Red	Net - RX+
	6	Black	Net - RX-
	7	---	---

Cable: CN4

Wire Application	Wire	Color	Description
RS-485 for Lift Controller	1	Thick Green	RS-485(B-)
	2	Thick Blue	RS-485(A+)

Cable: CN5

Wire Application	Wire	Color	Description
Anti-Tamper Switch	1	Red	N.C.
	2	Orange	COM
	3	Yellow	N.O.

Cable: CN6

Wire Application	Wire	Color	Description
Power	1	Red	DC 12V Output
Security trigger signal	2	Purple	Security trigger signal Output
Arming	3	Red White	Arming Output
Duress	4	Yellow White	Duress Output

Cable: CN9

Wire Application	Wire	Color	Description
TTL Output	1	Blue	CLK
	2	Red	DC 5V
	3	Orange	RX
	4	White	TE
	5	Yellow	TX
	6	Black	DC 0V

Wiring Diagram

Connect to Electric Bolt

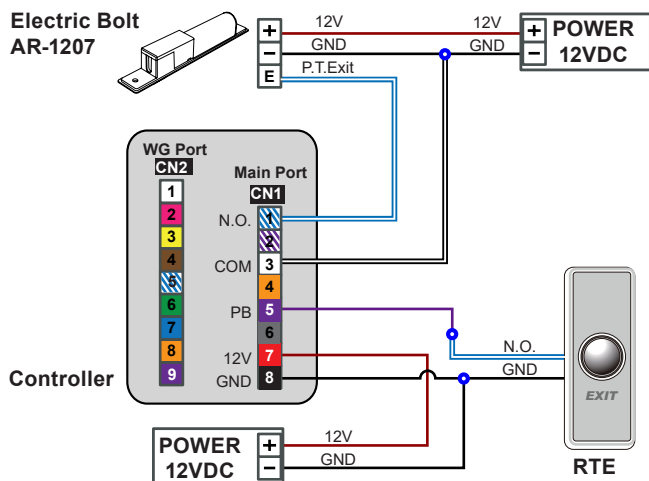

Connect to Magnet Lock

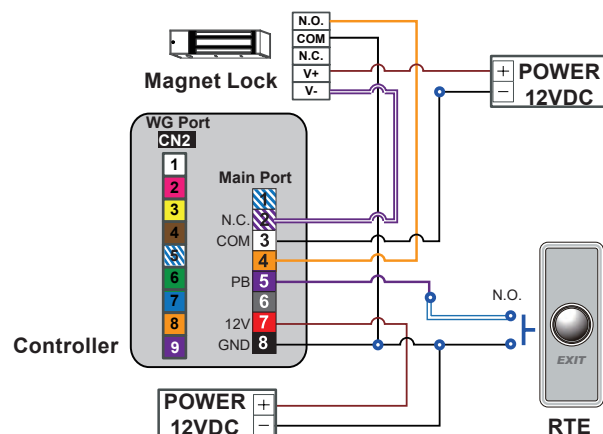

Connect to Electric Strike

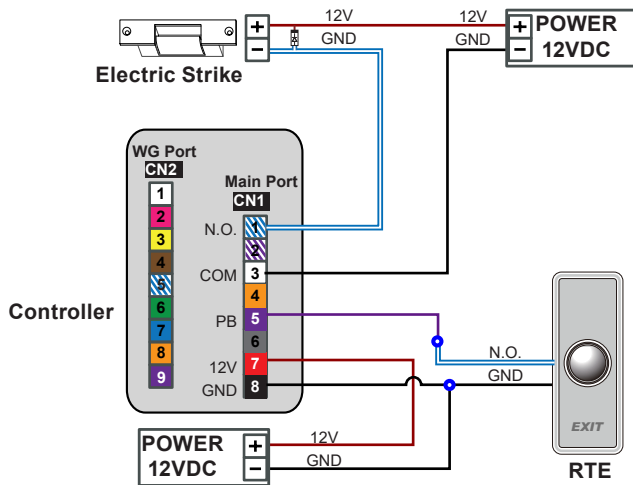

Connect to Door Sensor

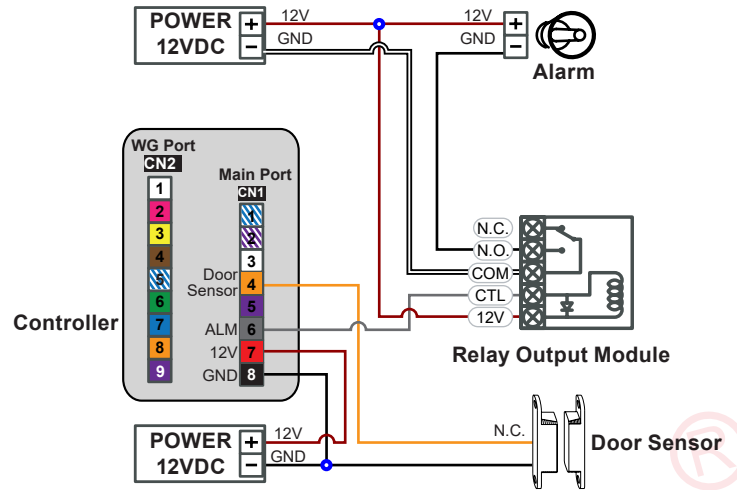

※ The Wiring of **Enable** "Share Door Relay" (Set up via the parameters setting Window of 701ServerSQL)

Strengthen security with Digital Relay Board

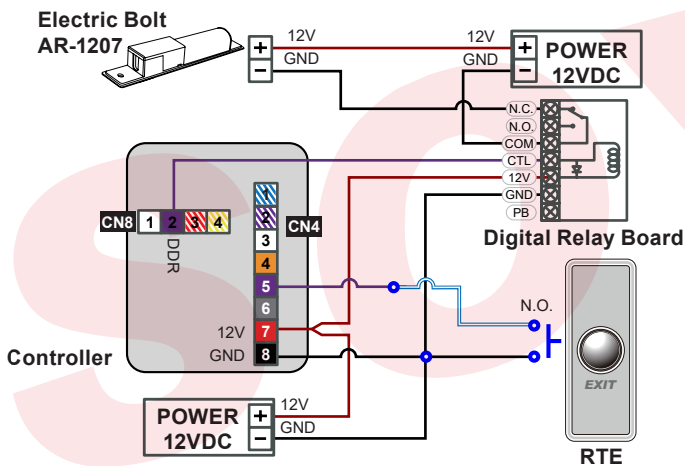

Connect to Reader

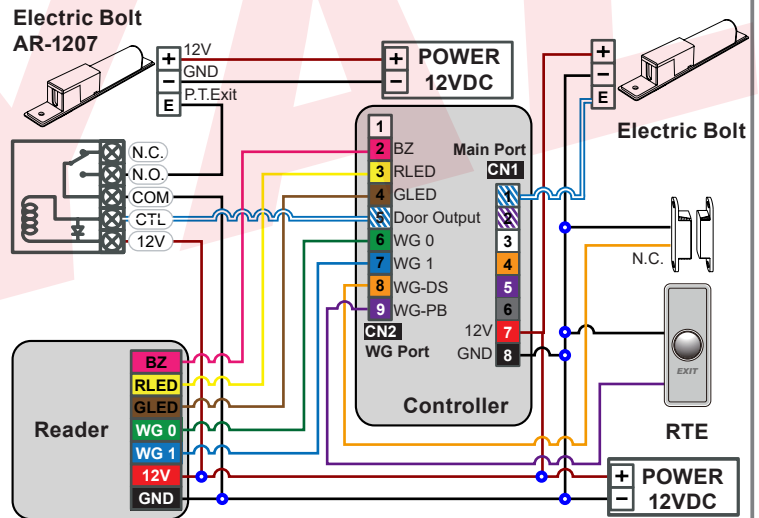

※ This wiring method is not eligible for "Share Door Relay" function (set up via parameter setting of 701ServerSQL). If there is external wiring to Wiegand reader, WG Port must enabled Digital Relay Output to enable "Share Door Relay" function.

※ The Wiring of **Disable** "Share Door Relay" (Set up via the parameters setting Window of 701ServerSQL)

WG Mode / Controller Mode Setting Method ,AR-331-E/EF become WG mode (28 * 000 #)

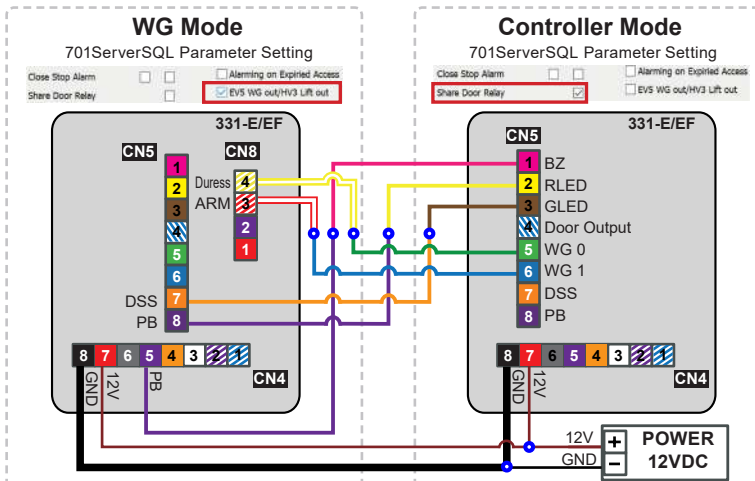

1. AR-331-E/EF can be set up as WG26/WG34/WG64 while the Controller is in WG Mode. These Controller can also be paired with the Controller that has WG input function.
2. AR-331-E/EF support Anti-pass-back by finger or card.
3. Networking Setting: Select E Series Controller Parameter Edit in 701Server, tick up the function "Ev5 WG out/Hv3 Lift out"
4. Please restart the controller after pressing "Write to Controller".

※Using Rule :

Finger : Both AR-331-EF Master mode and AR-331-EF WG mode must store all the same FP data and real or visual card number.

Card : Can pass WG message to controller.

Adding and Deleting Tag

Add New Tags

• Add by Presenting Tags (apply to Single Tag or a Batch of Tags)

※**Important Notice:** Please remember the last user address being added to make sure the old user data is not being over written with the new card in the future.

Add Non-consecutive Tags:

[Add single tag] Add a new tag for selected user address 100:

Enter program mode → 19 * 00100 * 00001 # → Present the tag → Successfully added tag of user 100

[Add 2 additional tags] Add new tags to the following user address 101-102:

Enter program mode → 19 * 00101 * 00001 # → Present (User 101) card → Present (User 102) card
→ Successfully added tags of user 101-102

[Add 10 additional tags] Add new tags to the following user address 103-112

Enter program mode → 19 * 00103 * 00001 # → Present (User 103) card → Present (User 104) card → Present (...) card
→ Present (User 111) card → Present (User 112) card → Successfully added tags of user 103-112

Add Consecutive Tags:

[Add 50 consecutive tags] Add 50 new tags with consecutive card number following user address 00050-00150:

Enter program mode → 19 * 00050 * 001001 # → Successfully added tags of user 50-150

Delete Tags

• Delete Single Tag or a Batch of Tags (by User Address)

Input * 123456 # (or Master Code) → 10 * SSSSS 9 EEEEE #

[e.g.] Delete User Address: 00058

Enter program mode → 10 * 00058 9 00058 #

[e.g.] Delete User Address: 00058~00063

Enter program mode → 10 * 00058 9 00063 #

• Delete All Tags

Input * 123456 # (or Master Code) → 29 * 29 * #

Tag Information (125kHz) ※ For Mifare tags, the separator between Site Code & Card Code is comma ",".



Programming

A. Entering and Exiting Programming Mode

• Entering

Input * 123456 # or * P P P P P #

[e.g.] The Default Value= 123456, if already changed the Master Code= 876112, input * 876112 # → Access programming mode

• Exiting

Input * #

• Changing the Master Code

Access programming mode → 09 * P P P P P P P P P P # [Input the 6-digit new master code twice.]

[e.g.] If want to changing the Master Code= 876112, input * 123456 # → 09 * 876112876112 #

B. Changing the Node ID of Reader

Access programming mode → 00 * N N N * M M M * A A A #

[NNN= Node ID: 000~254; MMM=AR-331-E/EF Door NO.:1~255; AAA=WG Reader Door NO.:1~255]

C. Setting up the control mode (M4/M8)

Access programming mode → 04 * N # [N=4/8]

Mode	Support	User Capacity	Access Mode	Event Capacity	120 Holidays	Duress	Time Zone	Lift Control	Anti-pass-back
M4	Networking/ Stand-Alone	16,000 (0~15,999)	1.Card only	32,000	V	V	unlimited	64	V
			2.Card and PIN (4-8 digit PIN Can be set)						
M8			3.Card or User address (5-digit) + Individual PIN (4-8 digit individual PIN Can be set)						
			1.Card only						
			2.Card and PIN (4-8 digit individual PIN Can be set)						
			3.Card or PIN (4-8 digit individual PIN Can be set)						

D. Setting up the password

• Individual PWD (M4/M8)

Card or PIN: Access programming mode → 12 * UUUUU * PPPP # [e.g. User address: 00001 and PWD: 1234. Input 12 * 00001 * 1234 #]

Card and PIN: Access programming mode → 13 * UUUUU * PPPP # [e.g. User address: 00001 and PWD: 1234. Input 13 * 00001 * 1234 #]

E. PIN & UID Length setting

• Access programming mode → 42 * m * n # [m=PIN code Length 4~8 Digit ; n= UID Length 2~8 Digit] (4 is default value)

Example: 42 * 8 * 4 # [PIN code Length 8 Digit ; UID Length 4 Digit]

F. Anti-pass-back

Usually, anti-pass-back is commonly applied to parking areas in order to prevent from multi-entry with one card at a time, or somewhere wants to monitor not only the access but also exit condition.

• Enable device

Access programming mode → 20 * 0 or 1 * ??? # 0 or 1= Enable target unit(0=Main Controller Parameter Setting,1=WG Input Port Parameter Setting)

[Please refer to [Compound Command Function List](#) for details.]

[e.g.] If the AR-331-E/EF set to exit reader, WG Reader set to access reader.

Access programming mode → 20 * 0 * 128 # → 20 * 1 * 192 # [Please refer to [Compound Command Function List](#) for details.]

• Enable card user

Access programming mode → 26 * SSSSS * EEEEE * P # SSSSS= starting user address; EEEEE= ending user address [P=0 Enable/ P=1 Disable/ P=2 Reset]

[e.g.] User address from 00152 to 00684 enable the anti-pass-back function: 26 * 00152 * 00684 * 0 #

G. Auto Open Access (uncontrolled) Time Zone – Automatically Release

Door will remain open after flashing one valid card. When the reader is stand-alone, supporting only 16 sets of auto-open zone by device setting.

Auto-open zone can extend up to unlimited sets by Networking.

Please refer to paragraph [Compound Command Function List](#) below to ensure command 20 * 0 or 1 * ??? # / 24 * 0 or 1 * ??? # will not reset the functions that already had been changed.

• Enable/Disable auto open zone

Access programming mode → 20 * 0 or 1 * ??? # 0 or 1= Enable target unit(0=Main Controller Parameter Setting,1=WG Input Port Parameter Setting)

[Please refer to [Compound Command Function List](#) for details.]

[e.g.] If the AR-AR-331-E/EF set to Enable aut open zone.

Access programming mode → 20 * 0 * 004 # [Please refer to function default value for details.]

• Enable/Disable auto open door without presenting one valid card

Access programming mode → 24 * 0 or 1 * ??? # 0 or 1= Enable target unit(0=Main Controller Parameter Setting,1=WG Input Port Parameter Setting) [Please refer to [Compound Command Function List](#) for details.]

[e.g.] If the WG Reader set to Enable aut open door without presenting card.

Access programming mode → 24 * 1 * 128 # [Please refer to function default value for details.]

• Setting up access time

Access programming mode → 08 * MW * NN * HHMMhhmm * 7123456H # [M=AR-331-E/EF; W=Reader(0=disable,1=enable); NN: 16 sets of auto-open zone (NN=00~15); HHMMhhmm=Starting time to ending time; 7123456H= 7 days of week + Holiday (F= 0: disable; 1: enable)]

[e.g.] AR-331-E/EF(without WG reader), to set second time zone which could be passed only at 9:30am to 4:20pm on Mon, Wed and Fri.

Access programming mode → 08 * 10 * 02 * 09301620 * 01010100 # → setting is completed

H. Lift control

Connect with AR-401-IO-0016R to control floors which the user will be able to access. [BAUD9600]

• Single floor

Access programming mode → 27 * UUUUU * LL #

UUUU=User Address LL=Floor number (01~64 floor)

[e.g.] User address NO. 45 only can reach the elevator to the 24th floor: 27 * 00045 * 24 #

• Multi floors

Access programming mode → 21 * UUUUU * G * LLLLLLLL #
 [UUUUU=User address G: 8 sets of lift control (Input: 0~7) LLLLLLLL:
 8 floors setting (L=0=Disable, L=1=Enable)

[e.g.] User address NO. 168 can reach only the 6th and 20th floor:

Access programming mode → 21 * 00168 * 0 * 00100000 #
 → 21 * 00168 * 2 * 00001000 # → OK (Please refer to floor chart as right.)

Please refer to below floor chart

Set (G)	Floor							
	L	L	L	L	L	L	L	L
0	8	7	6	5	4	3	2	1
1	16	15	14	13	12	11	10	9
2	24	23	22	21	20	19	18	17
3	32	31	30	29	28	27	26	25
4	40	39	38	37	36	35	34	33
5	48	47	46	45	44	43	42	41
6	56	55	54	53	52	51	50	49
7	64	63	62	61	60	59	58	57

I. Setting Up the Arming

In the security management of access control system, the controller or reader status is divided into Standby Mode or Disarming Mode and Arming Mode. The conditions for triggering the alarm in these two modes is different, as shown in the following comparison:

• Alarm conditions:

1. Door is forced open

• Application:

1. **Door open too long:** Door is open longer than door relay time plus door close time.
2. **Force open** (Opened without a valid user card): Access by force or illegal procedure.
3. **Door position abnormal:** Arming is enabled and the power is suddenly off then on.

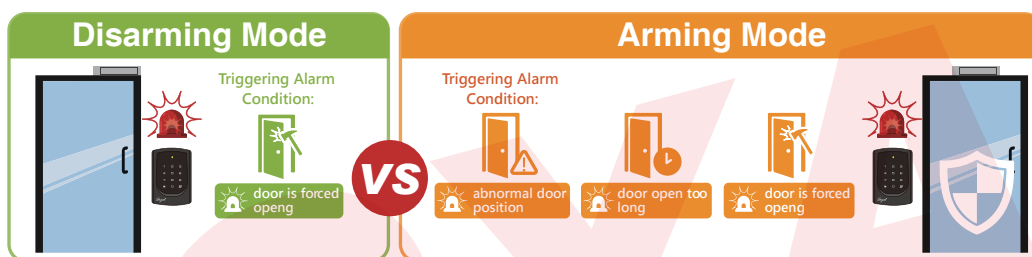

• Arming Setting and Alarm Trigger Procedure :

1. Normal Opening

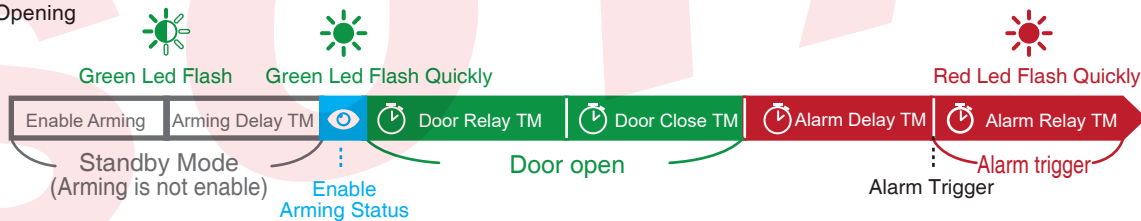

2. Abnormal Opening

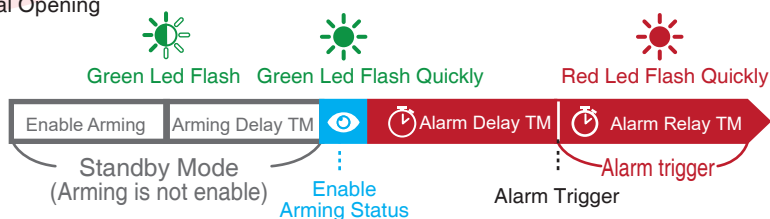

• Enable Arming status:

Standby Mode			
Card only		Card or Passcode	
Enable all devices	Enable particular device	Card or Passcode	Card and Passcode
Induct valid card → Input 4 digit arming code → * * #	Induct valid card → Input 4 digit arming code → * 0 or 1 # or #	Input 5 digit user address → Input 4 digit pass code → # → Input 4 digits arming code → * * # or * 0 or 1 #	Induct valid card → Input 4 digit pass code → # → Input 4 digits arming code → * * # or * 0 or 1 #
Enter Program Mode			
Enable all devices: Access programming mode → * * #		Enable particular device: Access programming mode → * * 0 or 1 #	

• Disable Arming status:

Standby Mode			
Card only		Card or Passcode	
Disable all devices	Disable particular device	Card or Passcode	Card and Passcode
Induct valid card → Input 4 digit arming code → * 9 #	Induct valid card → Input 4 digit arming code → * 0 or 1 # or #	Input 5 digit user address → Input 4 digit pass code → # → Input 4 digits arming code → * 9 # or * 0 or 1 #	Induct valid card → Input 4 digit pass code → # → Input 4 digits arming code → * 9 # or * 0 or 1 #

※ Factory default armingcode is: 1234. 0 or 1=Reader unit (0=Main Controller Parameter Setting,1=WG Input Port Parameter Setting).

J. Adding / Deleting Fingerprint

• Adding

Access programming mode → 3 9 * F * UUUUU # Place your finger on the sensor
 [F=1= Adding 1 Finger data; F=2= Adding 2 Finger data; UUUUU= User address]

How to add a finger data:

Adding 1 Fingerprint		Put 1st Finger	→ Bi	(After Bi sound, please remove the the finger from unit. Each finger shall collect for 3 times)	→ Long Bi (OK)
-----------------------------	---	----------------	-------------	---	-----------------------

※ Adding 2nd/3rd Fingerprint → Repeat 1st finger process

※ If you hear continuous "beep..." sounds when you place finger on the sensor, please release your finger from the sensor.

• Deleting

Access programming mode → 3 9 * 0 * UUUUU #
 UUUUU= User address

• Deleting All

Access programming mode → 3 9 * 9 * 99999 #

K. Enable/Disable Skip Finger/Tag





• Access programming mode → 4 0 * F * NNNNN * EEEEE #

NNNNN= starting user address

EEEEEE= ending user address

F= 1+3(Default Value)

(Please consult detail command on page 8.)

Command Setting	Software Setting	Access Mode	Way
40 * 1 * NNNNN * EEEEE #	<input type="checkbox"/> Just fingerprint	FP first and then Tag	First  + Then 
40 * 3 * NNNNN * EEEEE #	<input type="checkbox"/> Just card control		
40 * 0 * NNNNN * EEEEE #	<input checked="" type="checkbox"/> Just fingerprint	FP only or Tag only	 or 
40 * 2 * NNNNN * EEEEE #	<input checked="" type="checkbox"/> Just card control		

L. Adding / Deleting Fingerprint

1. For dual-fingerprint sensor module version, capacitive sensor module is the only enabled way for enrolling FP.
2. For dual-fingerprint sensor module version, user just can select one of fingerprint sensor for identification and can't put two fingerprints to different sensor at the same time.
3. Extra WG keypad panel is needed for adding card or downloading data connected to PC.
4. Each finger need to be collected 1 times enrolling for AR-331-E/EF.

M. The process of FP identification

1. While attached a finger on biometric sensor, there is a beep sound for starting the scanner. Then, please don't move your finger until the AR-331-EF makes another beep sound.
2. If there is a 8-beep sound after user gets access by FP, the FP data shall be reset by command 39*9*99999# under the programming mode.
 Cautions: Before reset the FP, please backup the data from source FP first.

Restoring Factory Settings

Reset all device parameters and user card data

• Reset User Data :

Access programming mode → 29 * 29 * #

• Reset User Data & Controller Parameter :

Access programming mode → 29 * 20 * #

• Reset User Data & Controller Parameter (incl. Master Code) & Reset Parameter Setting- SOR :

Access programming mode → 29 * 21 * #

• Reset IP Setting:

Access programming mode → Press "IP Resent Button" of main board for few seconds. (Reference to picture)

※ After operation as above, you will hear the long reminder sound, and wait until the sound disappear then reset the power of the controller, the device will restore factory setting.

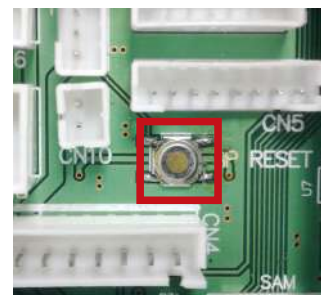

Firmware Upgrade

Get the upgrade software from SOYAL or our distributor and run "UdpUpdater" software

- Execute the software UDP Updater
The software is Login the SOYAL web to downloads

- Update the firmware
[Please login the SOYAL web to download the new ISP Firmware.]
 - Input the Target Address and Port
 - [Load F/W] open the documents that have the new ISP Firmware
 - Click the new ISP Firmware and [Open] it
 - Click [Update Device] to start the firmware update
 - Till the screen shown [Firmware Update is Complete]

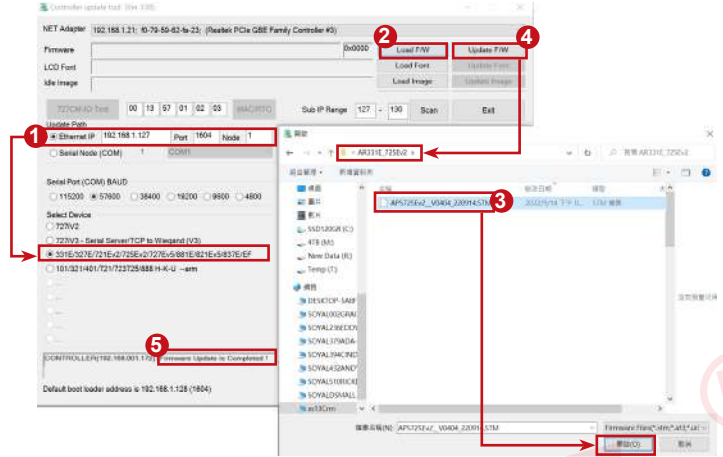

EnrollTool Setting

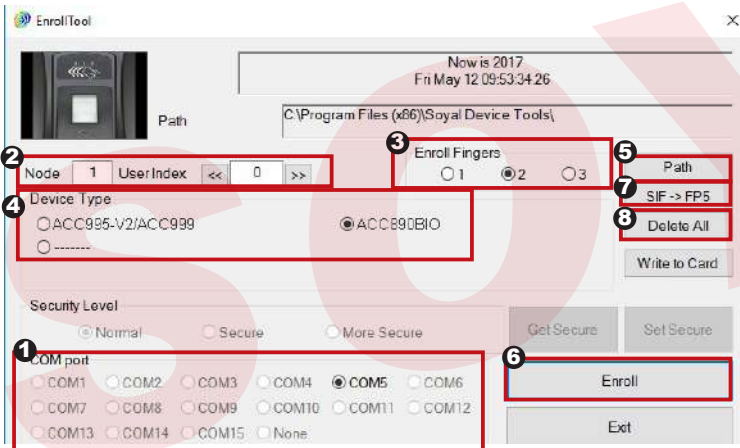

- Select correct "COM Port".
- Select "Node ID" of the device. Input "User Address".
- Select the number of enrolled fingers in assigned path (1FP or 2FP per User).
- Select the device type "AR-331-EF".
- Select "Save Path" in which will save fingerprint data.
- Click "Enroll", follow pop-up picture and Status bar to enroll FP as below:
Connect to Controller—> Place 1st finger 1st time to Finger sensor—> remove finger—> Place 1st finger 2nd time—> remove finger—> Place 2nd finger 1st time—> remove finger—> Place 2nd finger 1st time—> Save FP data to File—> Registration Completed.

Transfer fingerprint format V9 -> V5

- Click "SIF->FP5", select old AR-331EF FP file format. SIF, the system will automatically generate new single FP file format. FP5 into 701Server folder. FP5 into 701Server folder.

Deleting fingerprint database on the device

- Click "Delete All", all Fingerprint data from device will be deleted completely.

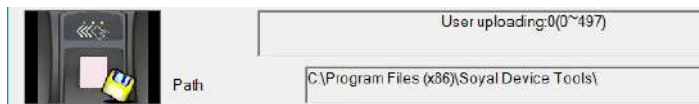

IP Setting

- Open your Web Browser and input factory default IP address: <http://192.168.1.127>

If the IP address of AR-331-E/EF has changed We must enter the new IP address.



- Page menu

[Current State](#)

Monitor the on-line computer

[Network Setting](#)

IP Setting

[User Password](#)

Change the Log-in information

- Current State

Online Status is able to monitor and show which computer is linking o Ethernet Module

Current IP Addresses					
Device Name	Type	IP address	Subnet mask	Gateway	DHCP
CONTROLLER	Ethernet	192.168.1.127	255.255.255.0	192.168.1.254	<input type="checkbox"/>

Current IP address of the AR-331-E/EF

- Log-in User Password

When you choose the "Networking Setting" or "User Password" at first.

Log-in window will pop out and please input

※ At the Factory Default

User name: SuperAdm

Password: 721568

NOTE :

- User Name is different from old and new version, password can be modify via [User Password] setting on the list but will not be change from updating new version. If you forgot the password, the solution is pressing Reset Button to reset it as default value.

Firmware Version	User name	Password (changeable)
After 2020/01/21	SuperAdm	Default Password : 721568 or self-definition
Before 2020/01/21	admin	Default Password : admin/ password not required or self-definition

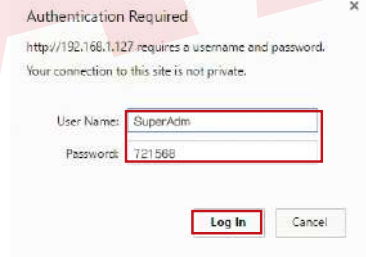

- Networking Setting

You will find initial IP Address 192.168.1.127 and check MAC Address is the same as sticker on Ethernet Module device. Please revise IP address you want, and then click "Update" button. After updating the IP, please re-connect the Web Browser by new IP address.

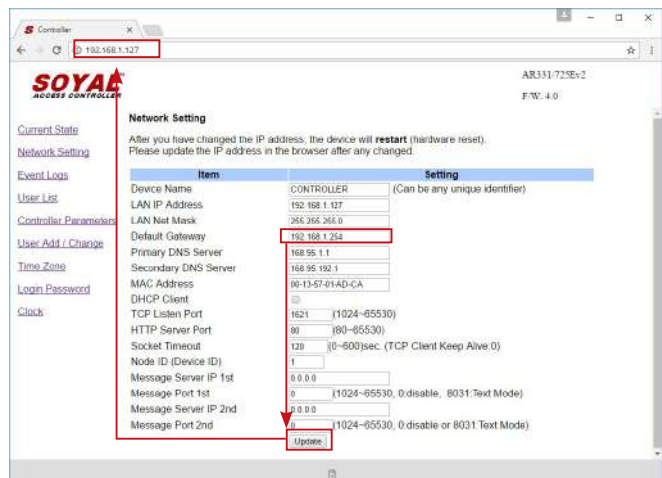

- User Password

Change the log-in password to lock the IP setting of Ethernet Module.

The password composes of 10 characters at most, it can be either A-Z or 0~9.

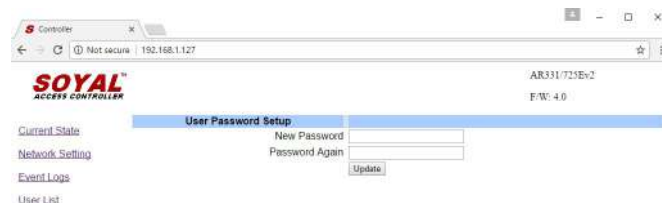

Command List (By WG Keyboard)		
Function	Command	Exposition
Entering programming mode	* PPPPPP #	PPPPPP: Master Code, (Default value: 123456)
Exiting programming mode	* #	
Exiting programming mode and enabling all device into arming status.	* * #	Including AR-331-EF, WG Reader
Enabling each device into arming status.	* * U #	U = Enable target unit (0=AR-331-EF , 1=WG Reader)
Node ID setting	00 * NNN * MMM * AAA #	NNN = Node ID, (001~254) MMM = AR-331-EF Door Number, (001~255) AAA = WG Reader Door Number, (001~255)
IP Address assign (Must power reset)	01 * 0 * CCCCCCCCCC #	default value = 192.168.1.127 CCCCCCCCCCCC = 192168001127 If set to 000.000.000.000 will enable DHCP otherwise will disable DHCP
	01 * 1 * 255255255000 #	Netmask
	01 * 2 * 192168001254 #	Gateway assign
Door relay time setting	02 * U * TTT #	U = Enable target unit (0=AR-331-EF , 1=WG Reader) TTT = Door relay time 000 (Output constantly) 001~600 = 1-600 Sec. ; 601~609 = 0.1~0.9Sec.
Alarm relay time setting	03 * TTT #	TTT = Alarm relay time ; 000 (Output constantly) 001~600 = 1~600 Sec.
Arming delay time setting	05 * TTT #	Base on second, range: 001~255
Alarm delay time setting	06 * TTT #	Base on second, range: 001~255
Master card setting	07 * SSSS * EEEEE #	SSSSS-EEEEEE = 00000~15999 SSSSS = starting user address; EEEEE = ending user address
Auto-open zone setting	08 * MW * NN * HHMMhmm * 7123456H #	M = AR-331-EF; W = WG Reader (0=disable; 1=enable) NN = 16 sets of auto-open zone (Range: 00~15) HHMMhmm = starting time to ending time (e.g.: 08301200=08:30 to 12:00) 7123456: 7 days of week -Sun/Mon/Tue/Wed/Thu/Fri/Sat (Input value: 0=disable; 1=enable) H: Holiday (Input value: 0=disable; 1=enable)
Master code settings	09 * PPPPPRRRRRR #	PPPPPP = New master code RRRRRR = Repeat the new master code
Suspend or delete tags	Suspend : 10 * SSSS * EEEEE # Delete : 10 * SSSS 9 EEEEE #	* : Suspend 9 : Delete SSSSS = starting user address; EEEEE = ending user address
Recover tag or change access mode from "Card and PIN" into "Card only"	11 * SSSS * EEEEE #	SSSSS = starting user address; EEEEE = ending user address
Modify the user's access PIN according to the user's address, and change the control mode to "Card or PIN"	12 * UUUUU * PPPP~PPPPPPP #	UUUUU = user address; PPPP~PPPPPPP = 4digit (default)~8-digit individual PWD (Access mode: Card or PIN)
Arming output setting	14 * TTT #	Base on 1ms, range: 1~255, default value = 10, Input 0 = Timeless
Duress code setting	15 * PPPP #	PPPP = 4-digit PWD (0001-9999) Default value : 4321 ※The Duress Code 0000 means that disable Duress Function and the default value is set as 0000 already.
Arming PWD setting	17 * PPPP #	PPPP = 4-digit PWD (0001-9999) Default value : 1234
Enabling or Disabling into arming status	Card + NNNN #	NNNN : Arming PWD U = Enable target unit (0=AR-331-E/EF, 1=WG Reader)
Enabling or Disabling each device into arming status.	Card + NNNN * U #	
Enabling all device into arming status.	Card + NNNN * * #	
Disabling all device into arming status.	Card + NNNN * 9 #	
Door open waiting time	18 * U * TTT #	U = Enable target unit (0=AR-331-EF , 1=WG Reader) TTT = Door open waiting time: 001~600; default value: 15 sec.
Add card by presenting	19 * UUUUU * QQQQQ #	UUUUU = user address QQQQQ = Card quantity (00001 = Continuously inducting)
Reader additional setting	20 * 0 or 1 * ??? #	0 or 1 = Enable target unit (0=AR-331-E/EF, 1=WG Reader) ??? = Function default value
Lift control setting: multi-doors	21 * UUUUU * G * LLLLLLL #	UUUUU = user address ; G = 4 sets of lift control (0~3); LLLLLLL = 8 assigned floor (F=0: Disable, 1: Enable)
Add/Delete tag by presenting (M6 only)	22 * N #	N=0 (Delete tag); N=1 (Add tag)
AR-401RO16/ AR-401RO16B relay time setting	23 * MMM * TTT #	MMM = Node ID of lift controller TTT = relay time: 000~600 = 1~600 sec.
Factory setting	24 * 0 or 1 * ??? #	0 or 1 = Enable target unit (0=AR-331-E/EF, 1=WG Reader) ??? : Function default value

Command List (By WG Keyboard)

Function	Command	Exposition
Real time clock setting	25 * Y Y M M D D H H M M S S #	YYMMDDHHMMSS = Year/Month/Day/Hour/Min./Sec.
Anti-pass-back (Enable user)	26 * S S S S S * E E E E E * P #	SSSSS= starting user address; EEEEE= ending user address P=0=Enable; P=1=Disable; P=2=Initial
Lift control setting: single door	27 * U U U U U * L L #	UUUUU= user address ; LL: Floor number(01~64 floor)
Duress Function and Arming output setting	28 * ? ? ? #	Arming output and Duress function: ???= 008 (default value)
Delete all tag/Delete all tag + parameters setting	29 * 29 * # / 29 * 299 #	
Same tag reading interval time	31 * T T T T #	Base on 10ms, range from 10 to 6000
Auto ring the clock alarm schedule	32 * S S * H H M M T T * 7 1 2 3 4 5 6 H #	SS= 16 sets auto alarm schedule, range 0~15 HHMM= HH:MM (ex. 0830: Ring bell at 08:30) TT=Period of time to ring bell (Base on second, range 01~99 sec.) 7123456: 7 days of week -Sun/Mon/Tue/Wed/Thu/Fri/Sat (Input value: 0=disable; 1=enable) H: Holiday (Input value: 0=disable; 1=enable)
Holiday Setting	35 * M M D D * F #	MM= Month of year (01=Jan...10=Oct.) DD= Date of month (01=1st day of month) F= 0:Delete ; 1: Add
Enabling or Disabling into Full Access status	36 * M W #	M=AR-331-EF ; W=WG Reader (0=disable; 1=enable)
RS485 port function setting (Needs to be restarted after setting)	37 * A B #	A=0:AR401RO B=0: 9600(default value) 1:Host (default value) 1: 19200 2:LED Panel 2: 38400 3:Printer 3: 57600
Adding / Deleting Fingerprint	39 * F * U U U U U #	F= 1: Adding one finger data / 2: Adding two finger data 3:Adding three finger data / 0: Delete
Deleting All Fingerprint	39 * 9 * 9 9 9 9 9 #	UUUUU= user address
En/Disable Skip Finger/Tag	40 * F * N N N N N * E E E E E #	First 40*1*NNNNN*EEEE# } setting a pair of command Then 40*3*NNNNN*EEEE# } Access mode: FP first and then Tag (Default Value)
Change WG bits output format	41 * n #	First 40*0*NNNNN*EEEE# } setting a pair of command Then 40*2*NNNNN*EEEE# } Access mode: FP only or Tag only NNNNN= starting user address;EEEE= ending user address
PIN & UID Length setting	42 * m * n #	n: 0=WG26 ; n: 1=WG34 m= PIN code Length 4~8 Digit n= UID Length 4~8 Digitn= UID Length 2~8 Digit

Compound Command Function List

Weighted Value Manual :

Step 1:

Select the "Function" that you need for each Compound Command category (20 *, 24 *, etc)

Step 2:

"Selection" of the function that you need is either have 0 or 1 value.

Step 3:

Subtract the "Value" of each Option with Selection.
Function = [0(deactive)*Value] ; [1(activate)*Value]

Step 4:

Add up all of the Function per Compound Command (20 *, 24 *, etc)

20 * 0 * ??? # (Main Controller Parameter Setting)

20 * 1 * ??? # (WG Input Port Parameter Setting)

※Default Value

Function	Option	Value	Bit	Application
Entry and Exit Access is recorded on Duty Report	※0: Yes 1: No	001	0	Networking
Activate close door automatically lock (Auto-Relock)	※0: Disable 1: Enable	002	1	Networking/Stand-Alone
Auto Open	※0: Disable 1: Enable	004	2	Networking/Stand-Alone
When Access Mode is "Card and PIN", Readers can skip pressing PIN code	※0: Disable 1: Enable	008	3	Networking/Stand-Alone
Exit by Push Button	0: Disable ※1: Enable	016	4	Networking/Stand-Alone
Enable force Open trigger alarm	※0: Disable 1: Enable	032	5	Networking
Entry/Exit Reader	※0: Exit 1: Entry	064	6	Networking
Anti-pass-back	※0: Disable 1: Enable	128	7	Networking

24 * 0 * ??? # (Main Controller Parameter Setting)

24 * 1 * ??? # (WG Input Port Parameter Setting)

※Default Value

Function	Option		Value	Bit	Application
Enable Egress Beep Sounds	0: Disable	※1: Enable	001	0	Networking/Stand-Alone
----	----	----	002	1	----
----	----	----	004	2	----
Arm/Disarm Zone(Zone: 62)	※0: Enable	1: Disable	008	3	Networking/Stand-Alone
Reader and controller share the same door relay (only for WG reader)	0: Disable	※1: Enable	016	4	Networking/Stand-Alone
◎Enable swipe any tags to release door open	※0: Disable	1: Enable	032	5	Networking/Stand-Alone
Stop alarm by pressing push button or closing the door	※0: Disable (must swipe valid card)	1: Enable	064	6	Networking/Stand-Alone
Enter auto open time zone without presenting valid card	※0: Disable (must present valid card first)	1: Enable	128	7	Networking/Stand-Alone

◎Add value 032 means to activate, deduct value of 032 means to deactivate the function of swipe any tags to release door open

28 * ???

※Default Value

Function	Option		Value	Bit	Application
Expiry User Access Trigger Alarm	※0: Disable	1: Enable	001	0	Networking/Stand-Alone
Reset Anti-Passback on Timezone 61	※0: Disable	1: Enable	002	1	Networking/Stand-Alone
---	----	----	004	2	----
Duress and Arming Output function	0: Wiegand Output	1: Arming and Duress Output	008	3	Networking/Stand-Alone
RS-485	Lift Control: 0		000	4-5	Networking/Stand-Alone
	Host: 1		016		
	LED Board: 1		032		
	Printer: 1		048		
----	----	----	032	6	----
----	----	----	064	7	----

34 * ???

※Default Value

Function	Option		Value	Bit	Application
Turn off buzzer function	※0: Disable	1: Enable	001	0	Networking/Stand-Alone
Any error trigger alarm (ex: swipe invalid card)	※0: Disable	1: Enable	002	1	Networking/Stand-Alone
Reserved	※0: Disable	1: Enable	004	2	Networking/Stand-Alone
Turn off 13.56MHz reading function	※0: Disable	1: Enable	008	3	Networking/Stand-Alone
Turn off 125kHz reading function	※0: Disable	1: Enable	016	4	Networking/Stand-Alone

44 * ???

※Default Value

Function	Option		Value	Bit	Application
Access valid door relay remain locked	※0: Disable	1: Enable	001	0	Networking/Stand-Alone
Master/Slave interlocking (Master open, Slave could not open door)	※0: Disable	1: Enable	002	1	Networking/Stand-Alone
Reserved	※0: Disable	1: Enable	004	2	Networking/Stand-Alone
Stop card access (access only by PIN or PC remote open door)	※0: Disable	1: Enable	008	3	Networking/Stand-Alone
Reserved	※0: Disable	1: Enable	016	4	Networking/Stand-Alone

 ※ More Details : [Introduction of New Function Commands for Enterprise E Controller and Home H Controller](#)